

# Saw Slide Chassis Upgrade - WCA400

Suits MK3 and early model Series 2000 Workcentres

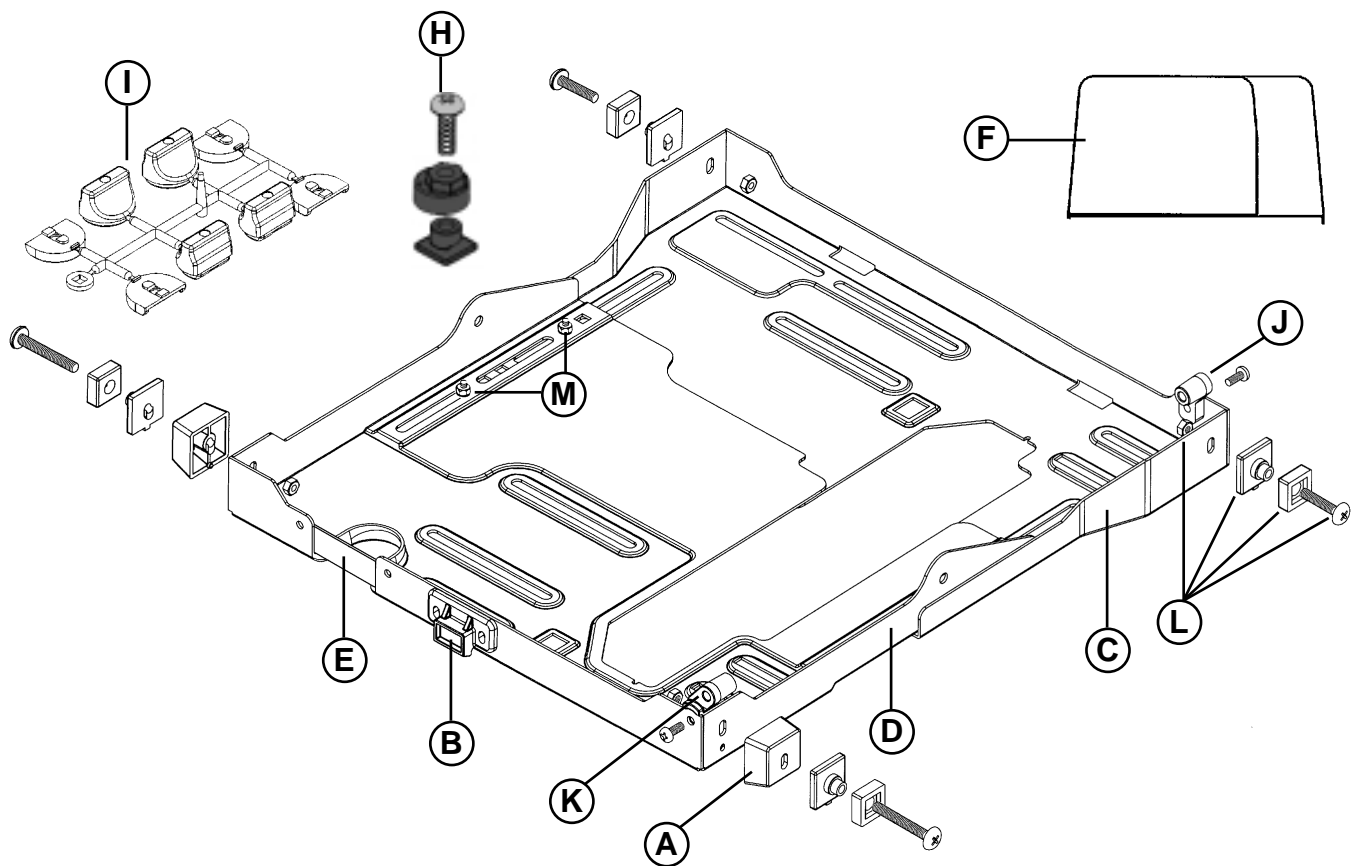

Diag. Ref.	Part No.	Description	Qty Supplied as Spare Part	Comments
	PUA383	Packing carton	1	
	PUA385	Instruction sheet	1	
A	WCA408	Bearing spacer	1	
B	WCA409	Chassis hook	1	
C	WCA403	Chassis - front	1	
D	WCA406	Chassis - rear	1	
E	WCA416	Chassis brace	1	
F	WCA388	Saw guard kit	1	Includes pivots & fasteners
G	WCA410	Fastener bag	1	
H	WCA417	Triton saw alignment cams	1	
I	CMA024	Saw clamps	1	
J	WCA411	Saw guard pivot - front	1	
K	WCA412	Saw guard pivot - rear	1	
L	WCA447	Bearing kit	1	
M	WCA398	Saw Chassis fastener sub bag	1	

## Specifications:

**Packed weight:** 3.875kg

**Packed Size:** 395 x 290 x 55mm

**Volume:** 0.063m<sup>3</sup>

**Paint:** Epoxy powder coat (oven cured) **Colour:** Telecom Gold